

Modular assembly of hot runner nozzles

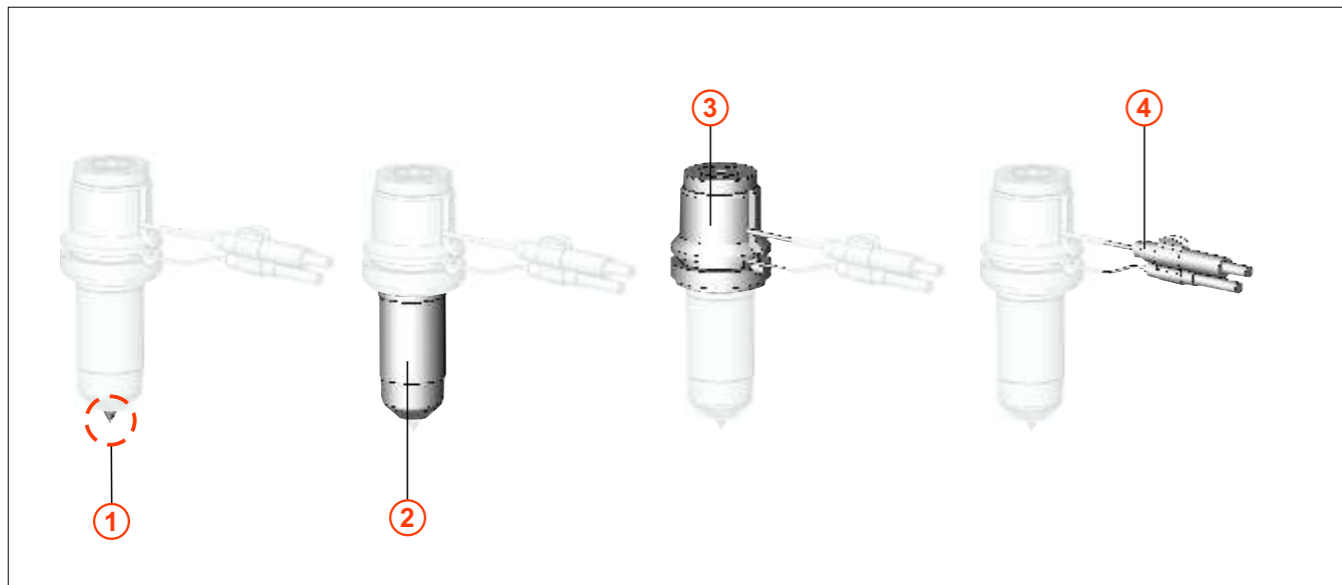

1 Nozzle piece open with tip

2 Nozzle shaft

3 Nozzle head

4 Power and thermocouple connection

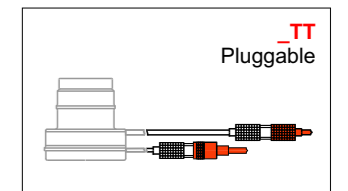
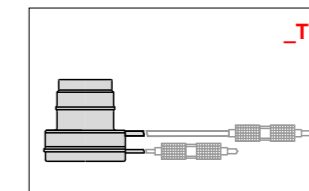
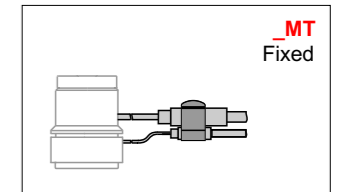
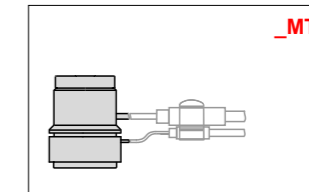
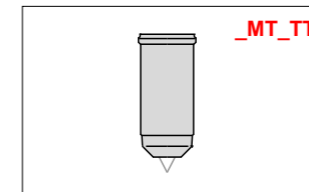
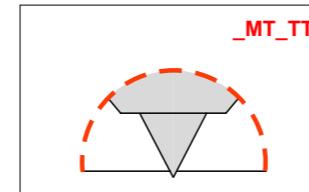

Flat nozzle

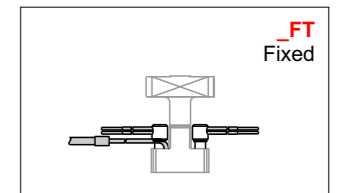
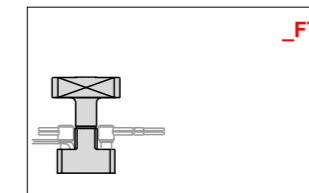
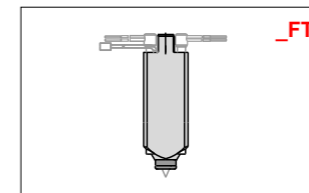
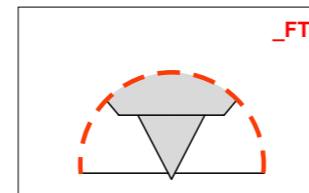

Nozzle without shaft

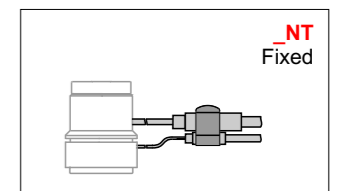
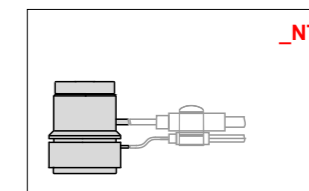
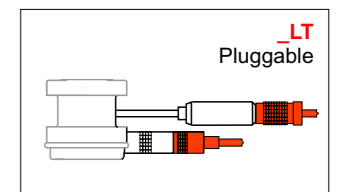
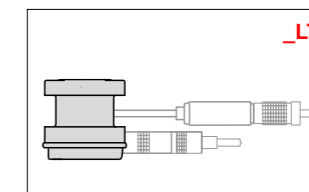
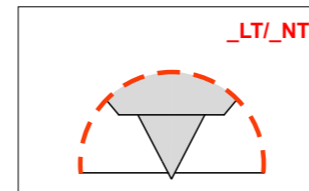

1 Nozzle piece open with tip

2 Nozzle shaft

3 Nozzle head

4 Power and thermocouple connection

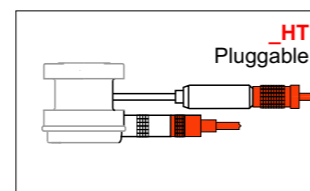
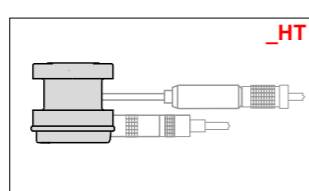
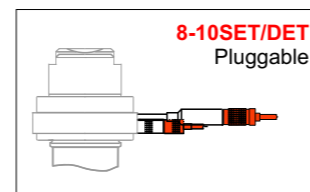
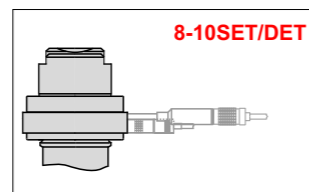
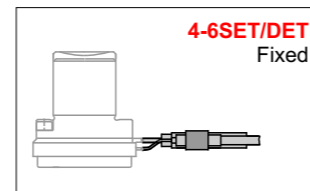
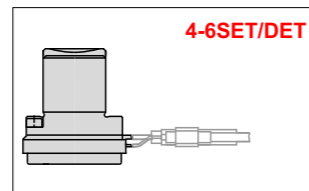
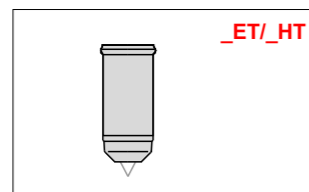
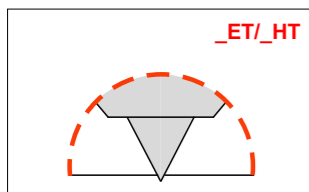

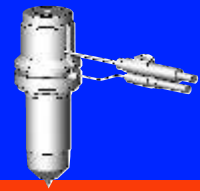

1 Nozzle piece

Open with tip

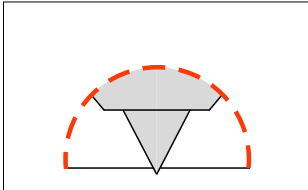

Open with gate without tip

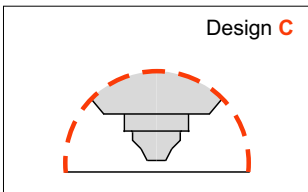

Open with gate without tip

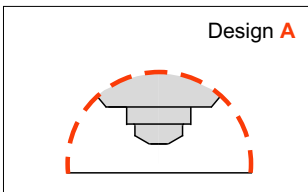

Gate bushing

Open nozzle with tip and open nozzle with gate without tip

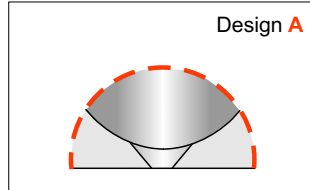

Open nozzle with gate without tip

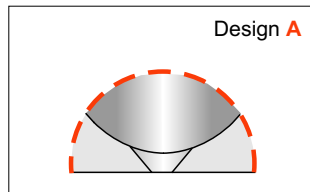

Open nozzle with gate without tip

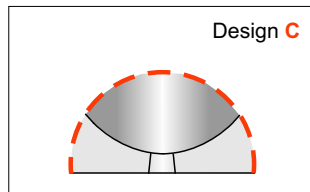

Assembly

Open nozzle with tip and open nozzle with gate without tip

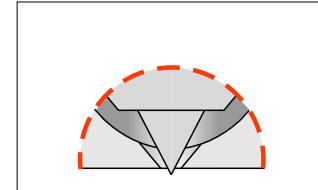

Open nozzle with gate without tip

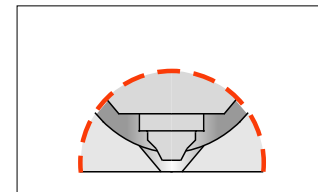

Open nozzle with gate without tip

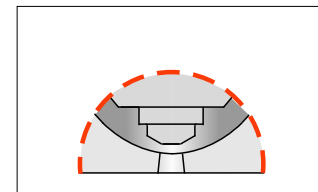

Valve gate nozzle

1 PM needle guide

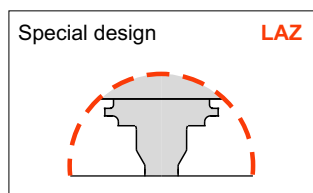
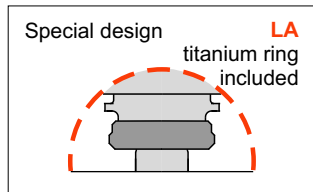
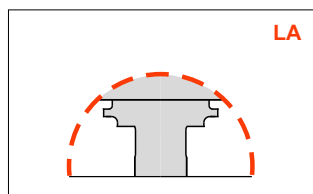

Gate bushing valve gate nozzles with PM needle guide

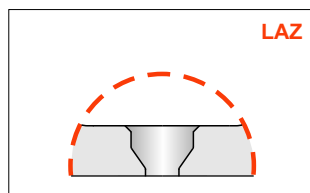
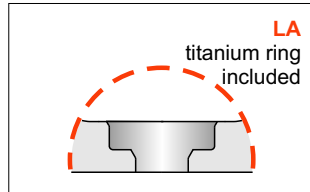
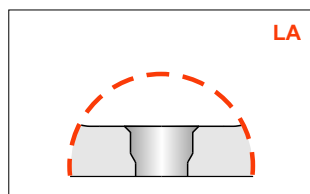

Assembly valve gate nozzles with PM needle guide

