



Side gating

The hot-runner nozzles for **side gating** give you the ideal scope in designing your hot-runner systems. Special attention was paid therefore to cost effectiveness and simple maintenance, for example hot-runner nozzle OktaFlow® with undivided inserts!
Optional: Nozzle tips made of wear protection for processing filled materials.

We shall be happy to provide an as-fitted drawing for your application.

26LHT hot-runner nozzle with up to 4 tips for side gating under 90° without cold slugs, in combination with a manifold. The individual nozzle tips cannot be influenced directly. **With divided inserts!**

NEW **Hot-runner nozzle OktaFlow® type OMT** with 8 tips for side multi-tip gating (under 90°) without cold slugs. Optimum temperature development thanks to heating in the nozzle tip area. Cost-efficient, that **undivided** inserts.
Hot-runner nozzle OktaFlow® can be used as a single nozzle with heated adaptor.

NEW **Hot-runner nozzle PektaFlow type PLT** with up to 24 tips for side multi-tip gating (under 90°) without cold slugs. Optimum temperature development thanks to heating in the nozzle tip area. To require **divided** inserts.
Hot-runner nozzle PektaFlow can be used as a single nozzle with heated adaptor.

Hot-runner nozzle type LHT

Example:

26 L H T S

S = Optional
 T = Voltage 230 V
 H = In combination with a manifold
 L = Side gating under 90°
 26 = Code for shaft diameter (S)

Optional

Example:

32/ 2/ 80 A V II

II = Tip design(I/II)
 V = Wear protection
 A = Plug position (A, B, C, D, E, F, G, H)
 80 = (L) Standard nozzle length (60, 80, 100)
 2 = Number of tips (1, 2, 3, 4)
 32 = Pitch circle diameter of the nozzle tip

Hot-runner nozzle OktaFlow® type OMT

Example:

8 O M T 120 - 45 / 8 S

S = Optional
 8 = Number of tips
 45 = Pitch circle-Ø the nozzle tip
 120 = (L) Standard nozzle length (50, 80, 120)
 T = Voltage 230 V
 M = Not screwed to the manifold, with shaft
 O = OktaFlow®
 8 = Code for material tube diameter (Ød)

S = Optional

V = Wear protection
 W = Heat conductive tube

Hot-runner nozzle PektaFlow type PLT

Example:

6 P L T 90 - 12/ 24 S

S = Optional
 24 = Number of tips (4, 6, 8, 12, 16, 24)
 12 = - mind. distance between the tip ≥12 mm
 - max. distance between the tip ≤132 mm
 90 = (L) Standard nozzle length
 T = Voltage 230 V
 L = Screwed to the manifold, without shaft
 P = PektaFlow
 6 = Code for material tube diameter (Ød)

S = Optional

V = Wear protection



- ① Power and thermo connection may be bent only **once** in this area. Minimum bend radius R8.
- ② The gate diameter D is dependent on the material used and part weight.

Please note:

1. Positive seal
When the hot runner system is cold, there is no positive seal between nozzles and manifold. It is necessary to reach operating temperature in order to seal the system.
2. Hot-runner nozzle
 - a. In case of limited installation space, the nozzle head can be flattened to fit the minension W she using the following nozzle types LHT
 - c. Take care with the metal o-rings when assembling; they provide sealing when warm. The metal o-ring are to be fixed in position in the groove with some grease.
 - d. Metal o-ring are included in delivery. Spare parts, chapter 7.
 - e. **After every disassembly a new metal o-ring must be inserted when refitting the nozzle, chapter 7.**
3. Pitch centers
The minimum pitch center depends of the pitch circle diameter on the nozzle type.
4. High temperature application
Please call our technical consulting if you have questions about high temperature applications **>320°C**.
5. Dimensions and tolerances
Dimensions and tolerances given refer to the mold.
6. Please see chapter 3 (yellow page) for the heat expansion gap dimension "K".
7. Maximum tightening torque

Threads	Property class	
	10.9	12.9
M4	3.8 Nm	4.6 Nm
M5	8 Nm	9.5 Nm
M6	13 Nm	16.0 Nm
M8	32 Nm	39.0 Nm
M10	64 Nm	77.0 Nm
M12	110 Nm	135.0 Nm

9. Technical information, chapter 1.4.

Important!

The nozzles must have an anti-tiwst protection!

Tolerance zone for the nozzle seat in the cavity plate:

Dimensions \varnothing H7	>10...18 =	$\begin{matrix} +0.018 \\ 0 \end{matrix}$
	>18...30 =	$\begin{matrix} +0.021 \\ 0 \end{matrix}$

Notes

Following parts must be ordered separately, chapter 6:

1. Thermo plug CMLK
nozzle type LHT
2. Power receptacle CMT
nozzle type LHT

If you have any questions please call our technical consulting at +49 (0) 6451 - 50 08-0.

Hot-runner nozzle OktaFlow® type OMT

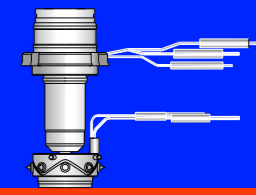

Assembly

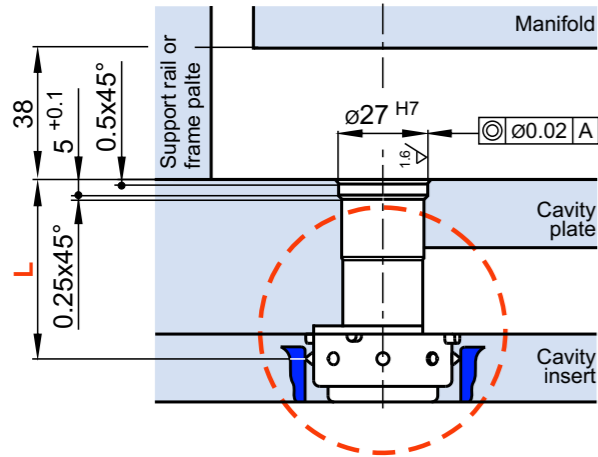

Detail X

To prevent jetting, inject against a core, for example.

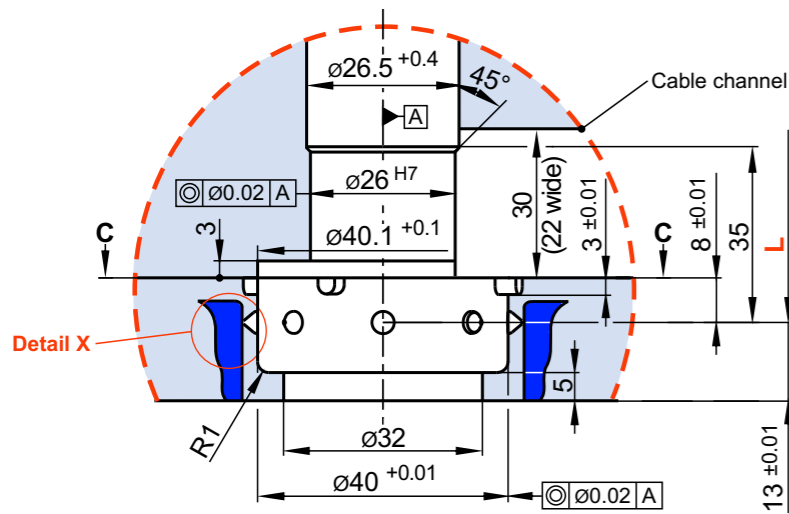
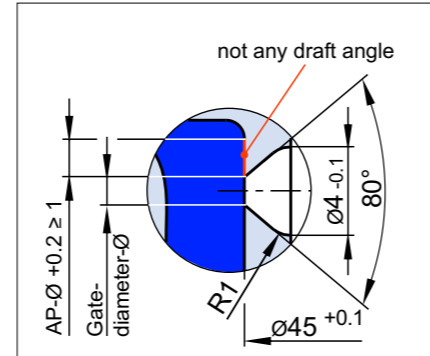

View C-C: Cavity insert

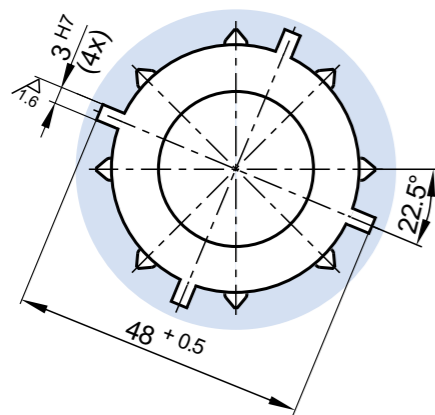

Order code

Example: Hot-runner nozzle 8OMT120-45/8-V

- 8 = Material tube- \varnothing d 6 mm
- OMT = O: OktaFlow®
M: not screwed to the manifold
T: Voltage 230 V
- 120 = Nozzle length 120 mm
- 45 = Pitch circle- \varnothing 45 mm
- 8 = Number of tips
- V = Wear protection

Please indicate the material type, article, part weight and nozzle length.

Notes

Hot-runner nozzles OktaFlow® type OMT are designed for the direct side gating of articles in compact, multi-cavity moulds. They allow a cost-effective mould construction, with undivided inserts.

- Tips individually replaceable on the machine
- Optimum temperature development thanks to heating in the nozzle tip area
- Supported on floating bearings and therefore independent of the thermal expansion

Single nozzle

Hot-runner nozzle OktaFlow® type OMT can be used as a single nozzle with heated adaptor.

- a) Fixed power connection incl. 2 m flexible cable
- b) Fixed thermo connection incl. 2 m flexible cable
- L: Measurement L refers to the gate diameter
- ① ...as well as further technical notes on the "yellow page".

Hot-runner-nozzle OktaFlow®

for side multi-tip gating under 90° without cold slug, in connection with a manifold

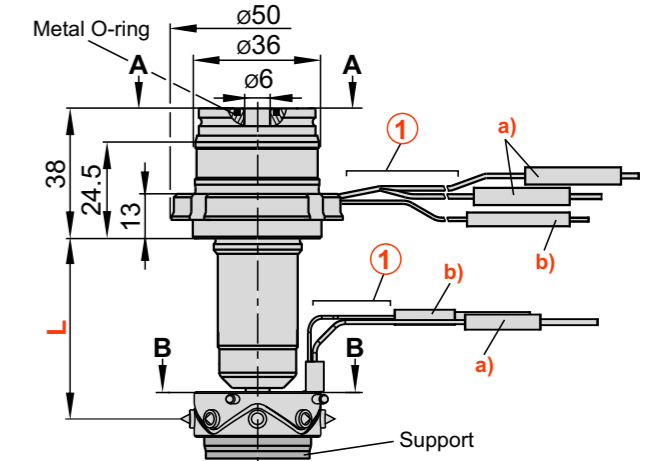

View A-A: Nozzle head

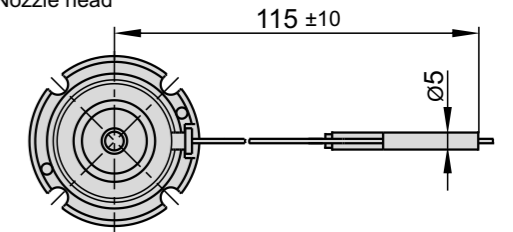

View B-B: Nozzle tip (drawing to a larger scale)

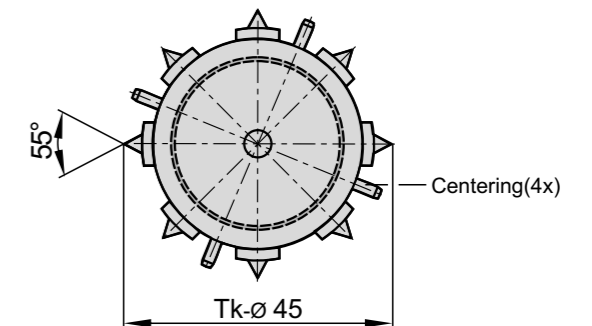

Delivery time

Nozzle type	Nozzle length L (mm)		
OMT	50	80	120
8	o	o	o

o = upon request